

Galaxy 3 Series Power Supply Unit

General Functional Description

The Galaxy 3 Series Power Supply Unit is available in 2 variants.

The **Galaxy Power Unit** is a 3 ampere power supply. The **Galaxy Power RIO** is a Power Unit plus an on-board Remote Input Output (RIO) module. Each variant can be integrated with all Galaxy control panels, with the exception of the Galaxy 8. The number of Power Units or Power RIO's that can be used on a system is limited by the number of RIO's that can be added to each panel. See the Control Panel Installation Manual for details of the numbers and addressing.

Battery

The minimum capacity battery to supply the PSU is 1x 7Ah. The maximum capacity battery to supply the PSU is 2 x 17Ah.

Battery Test

A battery test on full load is automatically performed once an hour and during the Engineer Mode exiting procedure. If the battery voltage falls to 10 V while the Power Supply Unit is running on the battery, then it is automatically disconnected to prevent deep discharge of the battery.

Smart Comms (Galaxy 18-512, G3-144, G3-520 only)

The total current used in the system is constantly measured and reported to the Galaxy control panel in the PSU comms menu option **61.4 = Diagnostics.PSU Comms**.

Galaxy control panel software (versions 1.04 and above), allow a battery size and stand-by time (menu option 51:36 and 51:37 respectively) to be entered. The Power Unit calculates the battery run time from the battery size and the load current. If the programmed stand-by time exceeds the calculated battery run time, a STANDBY TIME LOW message is displayed on the keypad on attempting to exit Engineer Mode.

Configuration

The Galaxy 3 Series Power Supply Unit (PSU) consists of 2 modules, the Power Block and the Control Unit. The PSU can be connected to the G3 control panel via the RS485 (AB) line. The PSU can be used in place of a standard RIO to overcome power problems that arise when the additional RIO is fitted distant to the control panel.

A 6-way jumper lead connects the Power Block to the Control Unit.

The Power RIO variant has 8 zones and 4 outputs. Addressing for either variant is identical to that described for RIO Modules.

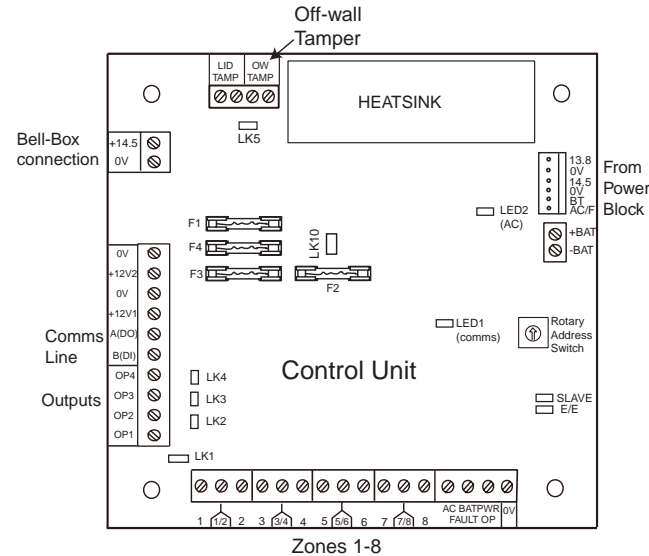

Figure 1. Control Unit

FAULT OP AC: This is an open collector transistor which is normally off. The output is activated by an AC failure.

FAULT OP BAT: This is an open collector transistor which is normally off. The output is activated by a Battery Low or Battery Fail condition.

FAULT OP PWR: This is an open collector transistor which is normally off. The output is activated by low voltage present in +12V1, +12V2.

The 4 outputs are switched 0V (0V active). Without the jumper links (LK1-4) fitted, the outputs will float in the OFF state. They can apply a +12V signal, if required, by fitting the appropriate pull-up jumper supplied.

LK5 will short out the off-wall tamper if it is not used.

The SLAVE and E/E links must be in place for normal operation.

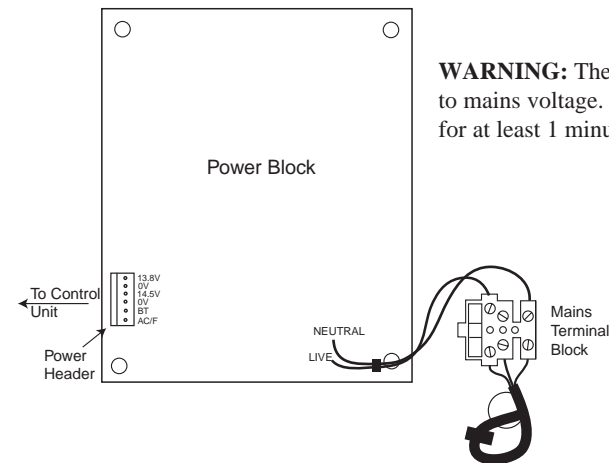

Figure 2. Power Block

Galaxy 3 Series Power Supply Unit

Installation Instructions

The installation and wiring must be performed by a competent engineer. The Galaxy 3 Series Power Supply Unit must be connected to the a.c. mains supply (230/240 V.a.c. 50Hz) via a fused connection outlet. The fuse in the mains outlet must not exceed 3A. The Power Supply Unit comes installed in the metal enclosure base. The installation procedure of the panel base is as follows:

1. Route the mains cable through the hole on the right hand side of the enclosure base. Securely anchor the cable to the box using the tie-wrap as shown in the following Figure:

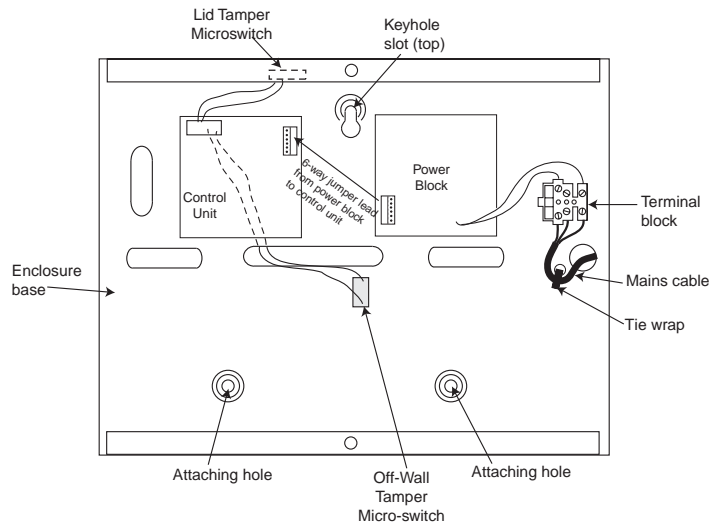

Figure 3. Enclosure Base

2. Secure the panel base to the wall using three 1.5" No. 8 roundhead steel screws through the holes provided. Ensure that the Off-wall tamper switch closes correctly.

The mains cable used must be a three core type (with green/yellow earth insulation) of adequate current carrying capacity.

NOTE: The mains cable must satisfy the requirements stated in BS6500.

3. Connect the mains cable to the mains terminal block as follows:
 - blue wire to the terminal marked N (Neutral)
 - green/yellow wire to the terminal marked (Earth)
 - brown wire to the terminal marked L (Live)

NOTE: No other connections to the mains connector are permitted.

All wiring must be in accordance with the latest edition of the IEE Wiring Regulations, BS7671 (Requirements for Electrical Installations).

4. Power up by applying mains first. This unit can be powered up from the battery by momentarily shorting LK10. Never leave LK10 connected, as deep discharge of the battery will occur. LK10 is for start-up only.

Specifications

Electrical (based on 34 Ah battery and UK grade 3 compliance)

Input voltage:	230V a.c. (+10%/-15%) @50Hz
Output voltage (nominal):	13.8V & 14.5V
Output current (max):	3.0A
Operating temperature:	-10 deg C to +40 deg C

Aux1 & Aux2

Output voltage (nominal):	13.8V
Output current (max):	0.75A each

14.5V Output (not for EN50131: grade 3 use)

Output voltage (nominal):	14.5V
Output current (max):	0.15A (when using this current, the AUX1 & AUX2 currents will be reduced by an equivalent amount).

Battery charge current (max):	1.4A
Maximum ripple voltage:	less than 100mV

Fuses

F1 (14.5V)	500mA - 20mm anti-surge
F2 (Battery)	1.6A - 20mm anti-surge
F3 (Aux1)	1.0A - 20mm anti-surge
F4 (Aux2)	1.0A - 20mm anti-surge

EN50131 Compliance

This product is suitable for use in systems designed to comply with EN50131-1:2004.

Security Grade - 3
Environmental Class - II
Power Supply Type - A



PD6662 Compliance

This product is suitable for use in systems designed to comply with PD6662:2004 at grade 3 environmental class II.